

UPUTSTVO ZA KORIŠĆENJE

MINIBAZEN TOPLOTNA PUMPA

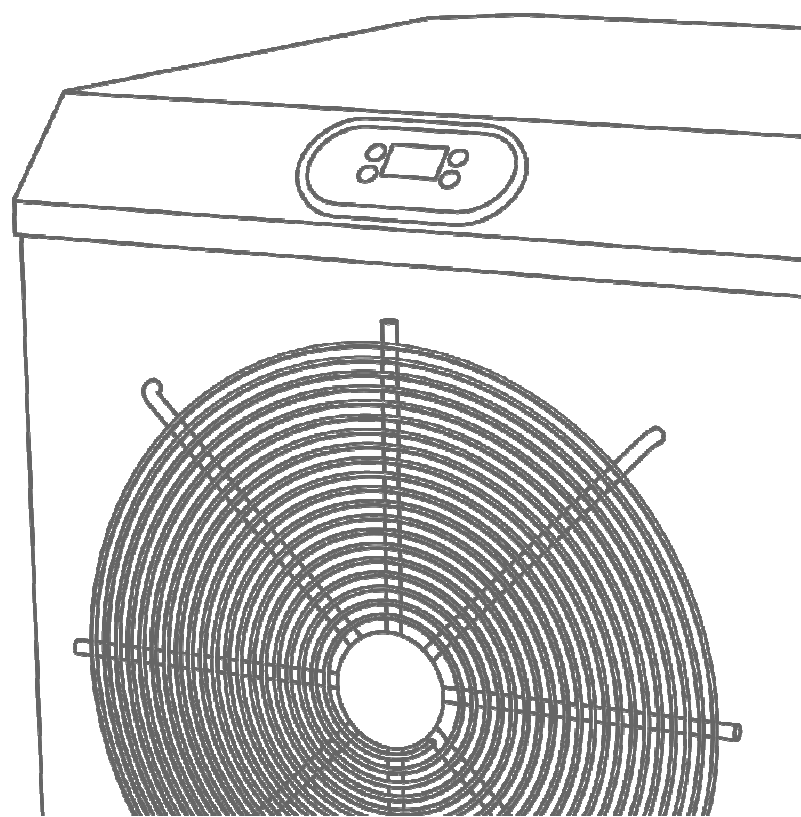

Sadržaj

1. Uputstvo za instalaciju i radne tačke.....	4
1.1 Lokacije instalacije	4
1.2 Proba	4
1.3 Povezivanje.....	5
1.4 Napajanje.....	6
1.5 Kondenzovana voda	7
2. Dimenzije	6
3. Tehnički parametar	8
4. Uputstvo za upotrebu.....	9
4.1 Prikaz temperature.....	9
4.2 Primena.....	9
5. Rešavanje problema	10
5.1 Rešavanje problema sa uobičajenim greškama.....	10
5.2 Kodovi grešaka	10
6. Svakodnevno održavanje i popravak proizvoda.....	11
6.1 Svakodnevno održavanje.....	11
6.2 Popravak proizvoda	11

UPUTSTVO ZA UGRADNJU I KORIŠĆENJE

Hvala vam što ste odabrali naš proizvod. Njegova primenljiva temperatura je 10-43 ° C.

▲ **Napomena:** Ovo uputstvo sadrži sve potrebne informacije za upotrebu i ugradnju toplotne pumpe.

▲ 1. Profesionalci ga moraju instalirati ili ukloniti,

▲ 2. Obavezno instalirajte odgovarajući prekidač

▲ Ako se pojave nenormalni uslovi (poput buke, mirisa, dima), odmah isključite napajanje i kontaktirajte prodavca, nemojte pokušavati da ga popravite sami, jer u suprotnom može da izazove opasnost.

▲ Glavni prekidač za napajanje treba postaviti u položaj do kojeg deca ne mogu da dođu, kako bi sprečilo decu da se igraju glavnim prekidačem za napajanje.

▲ 3. Ne stavljajte predmete poput ruku ili palica na ulaz i izlaz vazduha opreme i ne uklanjajte mrežicu ventilatora.

▲ 4. Glavni prekidač za napajanje treba postaviti u položaj do kojeg deca ne mogu da dođu, kako bi sprečio decu da se igraju glavnim prekidačem za napajanje.

▲ 5. Ne stavljajte predmete poput ruku ili palica na ulaz i izlaz vazduha opreme i ne uklanjajte mrežicu ventilatora.



Upozorenje:

- a. Molimo pročitajte sledeće savete pre instalacije, upotrebe i održavanja.
- b. Instalaciju, uklanjanje i održavanje mora izvoditi profesionalno osoblje u skladu sa uputstvima.
- c. Ispitivanje curenja gasa mora se obaviti pre i posle ugradnje.
 1. Korišćenje
 - a. Moraju ga instalirati ili ukloniti profesionalci, a zabranjeno je demontirati i popraviti bez dozvole.
 - b. Ne postavljajte prepreke pred ulaz i izlaz vazduha toplotne pumpe.

2. Instalacija

- a. Ovaj proizvod se mora držati dalje od izvora vatre.

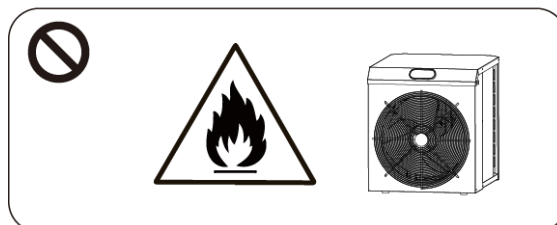

- b. Instalacija ne može biti u zatvorenom okruženju ili u zatvorenom i mora se dobro provetravati.

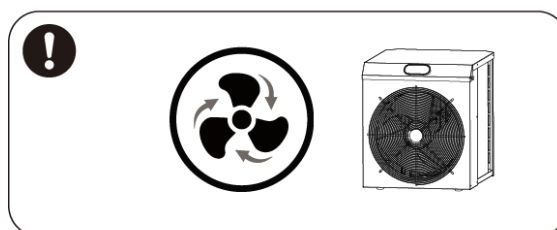

- c. Potpuno usisajte pre zavarivanja, zavarivanje na terenu nije dozvoljeno, zavarivanje može izvoditi samo profesionalno osoblje u profesionalnom centru za održavanje.

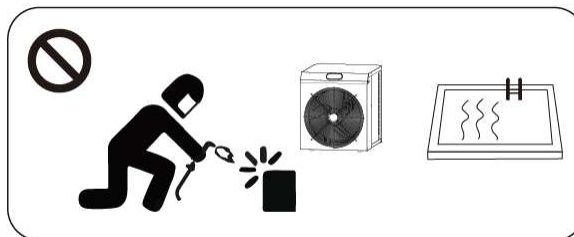

d.. Instalacija se mora zaustaviti ako dođe do curenja plina i jedinica se mora vratiti u centar za profesionalno održavanje.

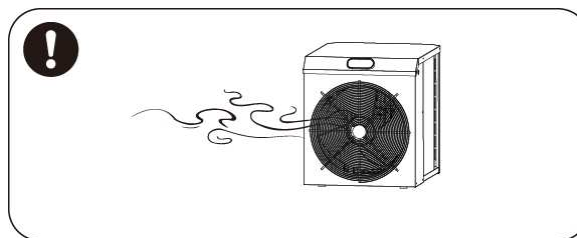

3. Transport I skladištenje

- a. Zaptivanje nije dozvoljeno tokom transporta
- b. Transport robe konstantnom brzinom potreban je da bi se izbeglo naglo ubrzanje ili naglo kočenje, kako bi se smanjio sudar robe.
- c. Jedinica mora biti daleko od izvora vatre.
- d. Prostor za odlaganje mora biti svetao, širok, otvoren i dobro provetran, potrebna je oprema za ventilaciju.

4. Obaveštenje o održavanju

- a. Ako je potrebno održavanje ili otpad, kontaktirajte ovlašćeni servisni centar u blizini
 - b. Kvalifikacioni uslov
 - c. Svi operatori koji odlažu gas moraju biti kvalifikovani važećom potvrdom koju je izdala profesionalna agencija.
- . Molimo vas da se strogo pridržavate zahteva proizvođača prilikom održavanja ili punjenja gasa. Molimo pogledajte uputstvo za tehničku uslugu.

1. Uputstvo za instalaciju i radne tačke

Opresz prilikom instalacije:

1. Svaka hemikalija mora biti dodata u cevi nakon toplotne pumpe (tj. Hemikalije ne mogu ući u toplotnu pumpu).
2. Kada postavljate ili transportujete opremu, treba je postaviti gore i držati je uspravno, i nesme se bacati ni okretati.

1.1 Lokacije instalacije

Proizvod se može instalirati i koristiti na bilo kojoj unapred određenoj lokaciji ukoliko su ispunjena sledeća tri uslova:

- 1) Dobra ventilacija
- 2) Stabilno napajanje
- 3) Filter bazena

Ova toplotna pumpa treba da se instalira na dobro provetrenom mestu spolja, a udaljenost od bazena treba da bude veća ili jednaka 2 metra. Izlaz mašine treba da bude udaljen najmanje 1 metar od prepreka, a okolne prepreke najmanje 0,5 metara. Ako je instaliran u zatvorenom, obratite se instalateru da bi se soba dobro provetravala.

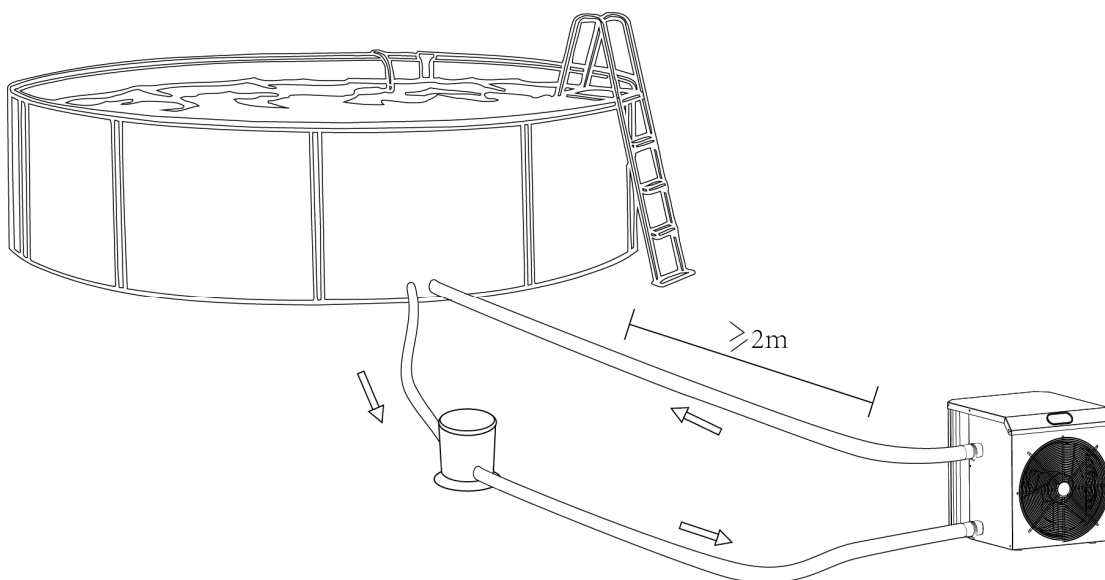

Napomena: Ne postavljajte jedinicu na ograničeno ili nedovoljno ventilaciono mesto ili na mesto gde može blokirati usis vazduha. Ova mesta mogu uticati na protok vazduha. To će dovesti do recirkulacije vazduha, što će rezultirati smanjenom efikasnošću. To čak može zaustaviti sistem da radi.

1.2 Proba

Napomena: Molimo osigurajte redosled „Pri pokretanju, pokrenite pumpu za vodu pre toplotne pumpe, Po završetku isključite toplotnu pumpu pre pumpe za vodu“, u suprotnom će oštetiti toplotnu pumpu.

1.3 Povezivanje

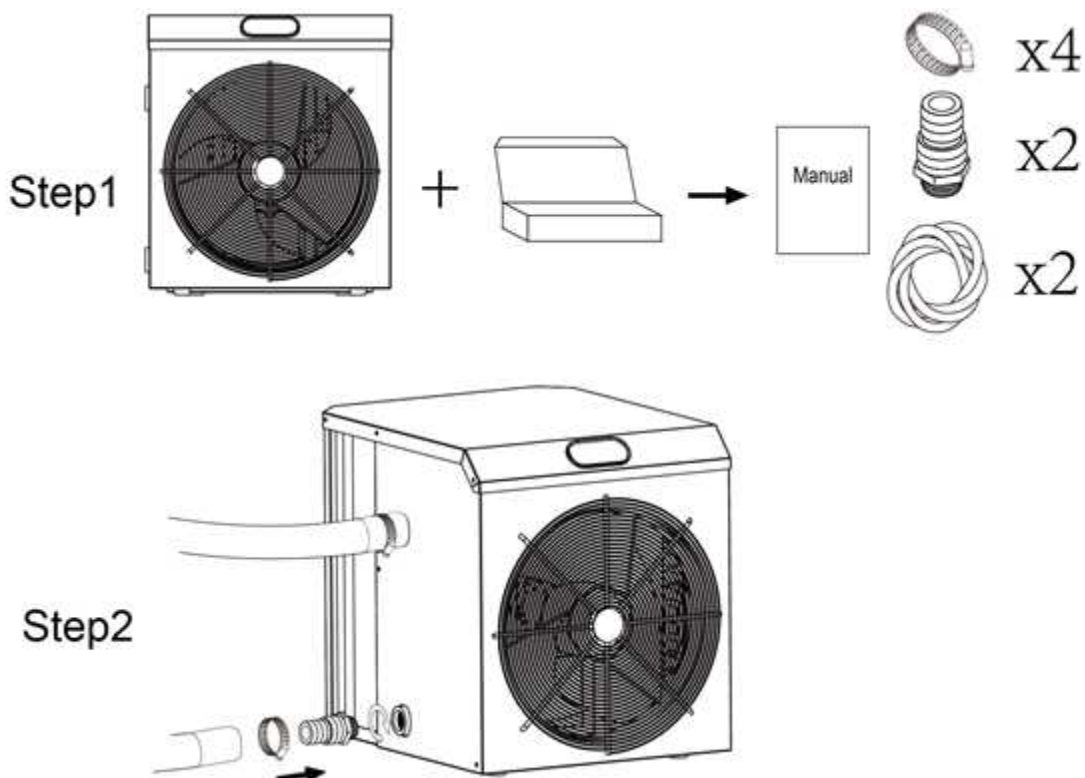

1.4 Napajanje

Pre povezivanja izvora napajanja, uverite se da se napajanje podudara sa nominalnim izvorom napajanja proizvoda.

Izbor kabla zaštitnog uređaja

Model		SHP03	SHP05	SHP06
Prekidač	Prekidač zaštitne sklopke	4.5	8.0	9.0
	Nazivna preostala struja curenja	30	30	30
Osigurač		4.5	8.0	9.0
Kabl za napajanje (MM2)		3×1.5	3×1.5	3×1.5

※Gore navedeni podaci mogu se izmeniti bez najave

Napomena: Gornji podaci su prilagođeni kablju za napajanje $\leq 10\text{m}$. Ako je kabl za napajanje $> 10\text{m}$, prečnik žice mora biti povećan. Signalni kabl se može produžiti na najviše 50 m.

Obratiti pažnju:

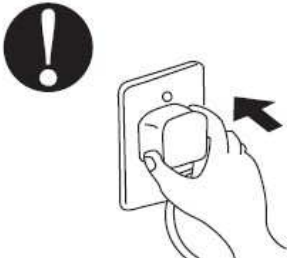
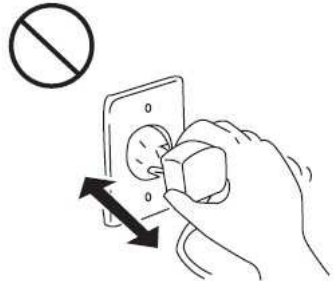
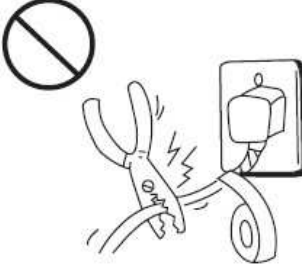
<p>Molimo osigurajte sigurnost utikača.</p> <p>U suprotnom može doći do strujnog udara ili požara.</p> 	<p>Ne isključujte napajanje dok mašina radi</p> <p>U suprotnom može doći do strujnog udara ili požara.</p> 	<p>Ne koristite oštećene ili nekvalitetne žice.</p> <p>U suprotnom može doći do strujnog udara ili požara.</p> 
--	--	--

Nakon što su sve veze dovršene i proverene, izvršite sledeće korake:

- 1) Korisnik prvo treba da pokrene pumpu za vodu kako bi se osiguralo curenje vode u sistemu vodovoda; zatim podesite termostat na odgovarajuću temperaturu nakon uključivanja.
- 2) Da bi zaštitila mašinu, ona ima funkciju odloženog pokretanja, nakon pokretanja, pokretanja pumpe za vodu, sledećeg ventilatora i kompresor će se automatski pokrenuti nakon otprilike 3 minuta
- 3) Proverite da li ima neobične buke tokom rada
- 4) Proverite da li je podešena temperatura odgovarajuća

U zavisnosti od početne temperature vode u bazenu i temperature vazduha, može biti potrebno nekoliko dana da se voda zagreje na željenu temperaturu. Dobar pokrivač bazena može u velikoj meri smanjiti potrebno vreme.

Vremensko kašnjenje - toplotna pumpa ima ugrađeno 3-minutno odlaganje pokretanja (pokreće se samo kada se zagreva) kako bi zaštitila kolo i izbegla česte prekidače koji uzrokuju gubitke. Uređaj će se automatski pokrenuti nakon perioda odlaganja. Čak i kratkotrajni prekid napajanja može pokrenuti ovo kašnjenje i zameniti ga curenjem sprečiti da se mašina odmah ponovo pokrene. Uključivanje i isključivanje tokom ovog kašnjenja ne utiče na trajanje odlaganja od 3 minuta

1.5 Kondenzovana voda

Vazduh koji ulazi u toplotnu pumpu snažno se hladi kada toplotna pumpa zagreva vodu u bazenu, što može prouzrokovati kondenzaciju rebara isparivača. Pri većoj relativnoj vlažnosti, kondenzacija može dostići nekoliko legla na sat. Ova pojava se ponekad zamenjuje sa curenjem.

2. Dimenzije

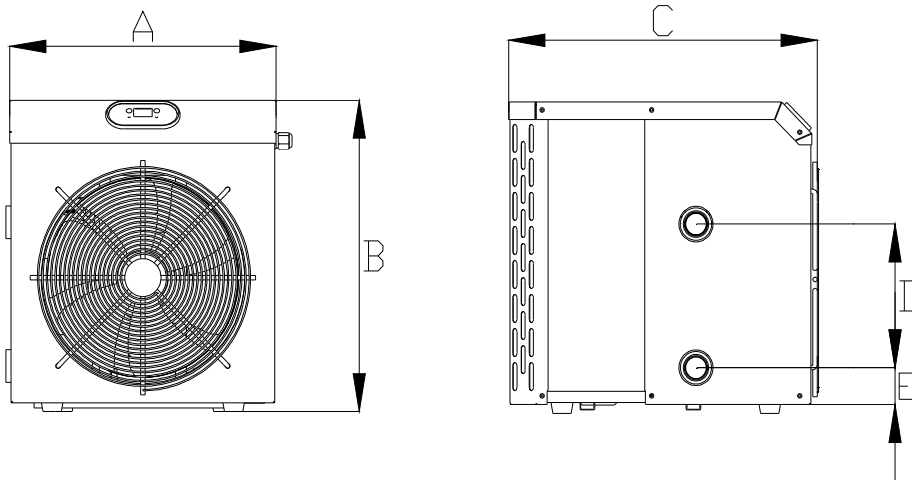

Veličina (mm) / Ime	A	B	C	D	E
Model					
SHP03	367	412	425	190	49
SHP05	445	484	503	300	49
SHP06	445	484	503	300	49

3. Tehnički parametri

Model	SHP03	SHP05	SHP06
Savetovani obim bazena	<20	<28	<35
Radna temperatura vazduha	10-43		
Uslovi performansi: Vazduh 26°C, Voda 26°C, Vlažnost 80%			
Heating capacity	3.5	5.8	7.0
Uslovi performansi :Vazduh 15°C, Voda 26°C, Vlažnost 70%			
Kapacitet zagrevanja	2.4	3.8	4.8
Napajanje	230V/50Hz/1PH		
Savetovani vodeni tok	1-2	2-3	3-4
Veličina izlaza za cev za vodu	32/38		
Neto dimenzije	412x367x425	484x445x503	484x445x503
Neto težina	24	34	38

Gore navedeni podaci mogu se izmeniti bez najave.

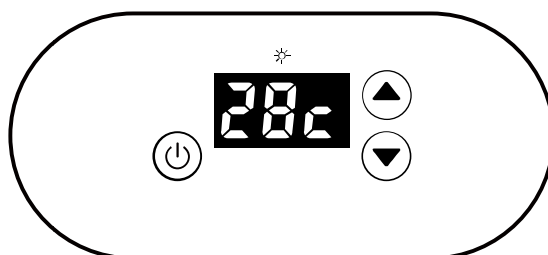

SIMBOL	OZNAKA	PRIMENA
	Uključivanje ON/OFF	Pritisnite za uključivanje ili isključivanje toplotne pumpe
	Gore/ dole	Pritisnite za podešavanje željene temperature vode

4.1 Prikaz temperature

28 °C je prikazano na ekranu kao dole za vašu referencu:

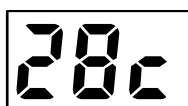

4.2 Primena

- 1) Uključivanje / isključivanje toplotne pumpe: kada se uključi, pritisnite za uključivanje / isključivanje.
- 2)) Podešavanje temperature vode: Kada je toplotna pumpa uključena, pritisnite or za promenu podešene temperature vode.
- 3) 3) Tokom grejanja, „☀“ će svetleti: temperatura vode se može podesiti na (18 ~ 40 °C)
- 4) Odmrzavanje

Automatsko odmrzavanje: Kada uđete u funkciju automatskog odmrzavanja, ikona na vrhu ekrana će treptati; Kada završi odmrzavanje, mašina se automatski prebacuje na funkciju grejanja, ☀ a ikona ostaje osvetljena.

Napomena: Toplotna pumpa može da radi samo dok sistem za cirkulaciju / filtraciju vode radi.

5.1 Rešavanje problema sa uobičajenim greškama

GREŠKE	RAZLOG	REŠENJE
Toplotna pumpa ne radi	Nema napajanja	Sačekajte dok se napajanje oporavi
	Prrekidač za napajanje je isključen	Uključite napajanje
	Osigurač je izgoreo	Proverite i promenite osigurač
	Prekidač je isključen	Proverite i uključite prekidač
Ventilator radi, ali sa nedovoljnim zagrevanjem	Isparivač blokiran	Uklonite prepreke
	Izlaz vazduha je blokiran	Uklonite prepreke
	3 minuta odlaganja starta	Sačekajte strpljivo
Ekran je normalan, ali nema grejanja	Podesi temp. preniska	Podesite odg. temperaturu grejanja.
	3 minuta odlaganja starta	Sačekajte strpljivo
Ako gornja rešenja ne funkcionišu, kontaktirajte svog instalatera sa detaljnim informacijama i brojem modela. Ne pokušavajte da ga popravite sami.		

Napomena: Ako se dogode sledeći uslovi, odmah zaustavite mašinu i odmah isključite napajanje, a zatim kontaktirajte svog prodavca:

- a) netačno prebacivanje
- b) Osigurač je često prekinut ili je preskočio prekidač curenja.

5.2 Greške u kodovima

KOD GREŠKE	OPIS GREŠKE
PP1	Kvar senzora temperature ulaznog voda
PP2	Neuspeh senzora da poveže AIN2 terminal na PC ploči
PP3	Neuspeh senzora da poveže AIN3 terminal na PC ploču
PP4	Kvar senzora temperature povratka gasa
PP5	Kvar senzora temperature vazduha
PP7	Temperatura ambijenta za grejanje preniska zaštita
EE1	Zaštita od visokog pritiska
EE2	Zaštita od niskog pritiska
EE3	Kvar prekidača protoka vode

6. Svakodnevno održavanje i popravak proizvoda

6. 1 Svakodnevno održavanje

- a) Pravilno podesite temperaturu i vlažnost za ugodno okruženje, izbegavajte pregrevanje ili prekomerno hlađenje.
- b) Ne postavljajte prepreke pred ulaz i izlaz vazduha toplotne pumpe, jer će efikasnost toplotne pumpe biti smanjena, čak i ako je toplotna pumpa zaustavljena.
- c) Ne stavljajte ruku ili štap u ulaz ili izlaz, nemojte uklanjati mrežicu ventilatora, jer bi ventilator koji radi mogao da vam nanese štetu.
- d) Ne koristite i ne skladištite zapaljivi gas ili tečnost kao što su razređivači, boja i gorivo kako biste izbegli požar.
- e) Mašinu ne ispirajte direktno vodom. Za čišćenje se preporučuje upotreba neutralnog deterdženta za domaćinstvo ili vode. Strogo je zabranjeno koristiti isparljivo ulje, benzin, razređivač i druge supstance.
- f) Molimo vas da redovno čistite bazen i sistem za filtriranje kako biste izbegli oštećenje uređaja zbog začepljenja filtera.
- g) Bez upotrebe zimi, prekidač za napajanje mora biti isključen; odvrnite dovodnu cev da biste očistili vodu unutar mašine.
- h) Redovno proveravajte da li su zavrtnji olabavljeni, proverite da li su žice istrošene ili ne i da li su veze sigurne. Ili ne, i da li su veze sigurne..

6. 2 Popravka proizvoda

- a) U slučaju nenormalnih uslova (nenormalna buka, miris, dim, curenje električne energije itd.), odmah prekinite napajanje, a zatim se obratite lokalnom distributeru i obavestite model proizvoda i detalje kvara. To mora popraviti stručnjak. Nemojte ga sami rastavljati i popravljati kako biste izbegli opasnost!
- b) Pre otkrivanja i popravke mašine, morate potvrditi da je mašina isključena i isključena iz napajanja; prilikom otvaranja poklopca električne kutije mora se potvrditi da su svi indikatori u električnoj kutiji ugašeni pre rada.

INSTALLATION AND USER MANUAL

MINI SWIM POOL HEAT PUMP

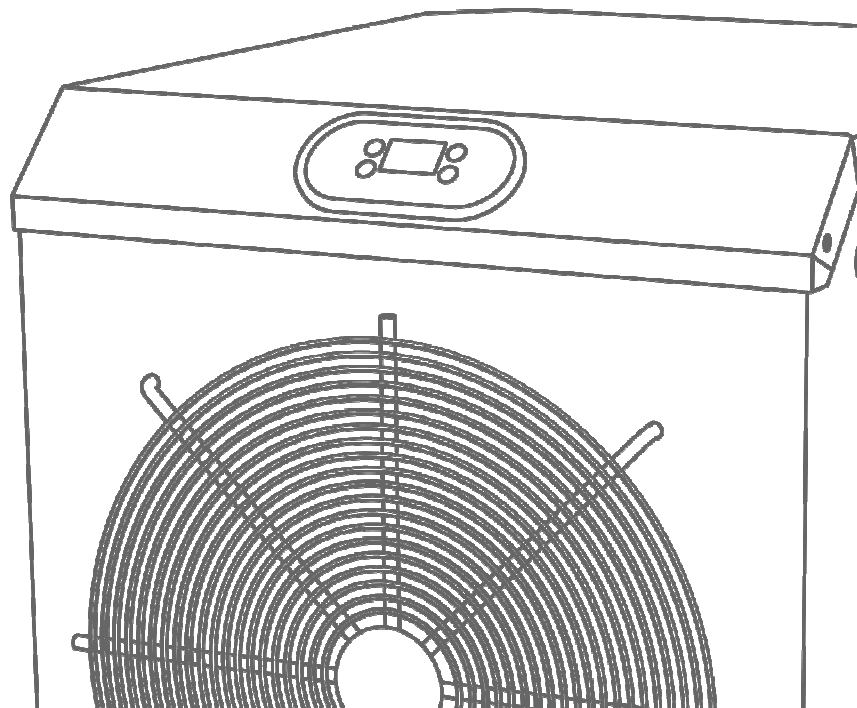

Content

1.	Installation instruction & Operation Points.....	4
1.1	Installation Locations.....	4
1.2	Trial.....	4
1.3	Connection.....	5
1.4	Power Supply.....	6
1.5	Condensate water.....	7
2.	Dimension.....	6
3.	Technical Parameter.....	8
4.	Operation instruction.....	9
4.1	Temperature display.....	9
4.2	Operation.....	9
5.	Trouble Shooting.....	10
5.1	Trouble shooting for common faults.....	10
5.2	Failure code.....	10
6.	Daily Maintenance and Product Repair.....	11
6.1	Daily maintenance.....	11
6.2	Product Repair.....	11

INSTALLATION AND USER MANUAL

Thank you for choosing our product. Its applicable temperature is 10-43 °C.

▲ Note: This manual contains all the necessary information to use and install the heat pump.

1. It must be installed or removed by professionals,
2. Be sure to install a suitable circuit breaker

If abnormal conditions (such as noise, smell, smoke) occur, please immediately turn off the power and contact the seller, do not try to repair it yourself, otherwise it may cause danger.

The main power switch should be placed in a position that children cannot reach, in order to prevent children from playing with the main power switch.

3. Do not put objects such as hands or sticks into the air inlet and outlet of the equipment and do not remove the fan mesh.
4. The main power switch should be placed in a position that children cannot reach, in order to prevent children from playing with the main power switch.
5. Do not put objects such as hands or sticks into the air inlet and outlet of the equipment and do not remove the fan mesh.



Warning:

- a. Please read the following tips before installation, use and maintenance.
- b. Installation, removal and maintenance must be carried out by professional personnel in accordance with the instructions.
- c. Gas leakage test must be done before and after installation.

1. Use

- a. It must be installed or removed by professionals, and it is forbidden to dismantle and refit without permission.
- b. Don't put obstacles before the air inlet and outlet of the heat pump.

2. Installation

- a. This product must be kept away from any source of fire.

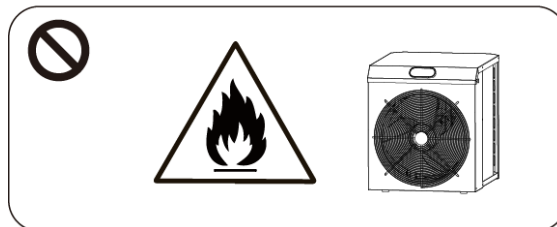

- b. The installation can't be in a closed environment or indoors, and must be kept well ventilated.

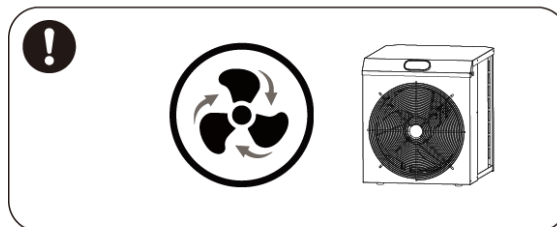

- c. Vacuum completely before welding, field welding is not allowed, welding can only be performed by professional personnel in professional maintenance center.

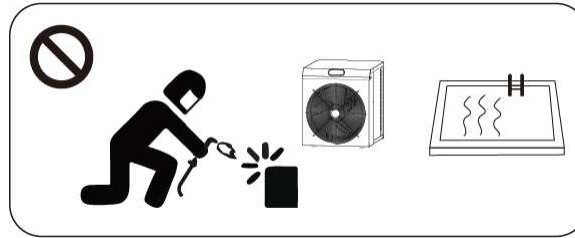

- d. Installation must be stopped if any gas leakage, and the unit must be returned to professional maintenance center.

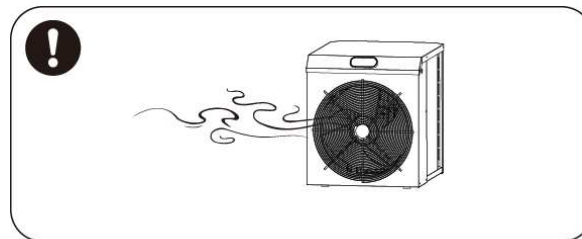

3. Transportation & Storage

- a. Sealing is not allowed during transportation
- b. Transporting goods at a constant speed is needed to avoid sudden acceleration or sudden braking, so as to reduce the collision of goods.
- c. The unit must be far away from any source of fire.
- d. Storage place must be bright, wide, open and good ventilation, ventilation equipment is required.

4. Maintenance Notice

- d. If maintenance or scrap is required, contact an authorized service center nearby

e. Qualification requirement

All operators who dispose gas must be qualified by valid certification which issued by professional agency.

- f. Please strictly comply with the requirement from manufacturer when maintenance or filling gas. Please refer to the technical service manual.

Cautions of Installation:

1. Any chemicals must be guaranteed to be added to the pipes after the heat pump (ie, the chemicals cannot enter the heat pump).
2. When placing or transporting the equipment, it should be placed upwards and kept upright, and must not be dumped or inverted.

1.1 Installation Locations

The product can be installed and used at any predetermined location as long as the following three conditions are met:

- 1) Good ventilation
- 2) Stable power supply
- 3) Pool filter

This heat pump should be installed in a well-ventilated place outside, and the distance from the swimming pool should be greater than or equal to 2 meters. The machine outlet should be at least 1 meter away from the obstacles, and the surrounding obstacles should be at least 0.5 meters. If installed indoors, please consult the installer to keep the room well ventilated.

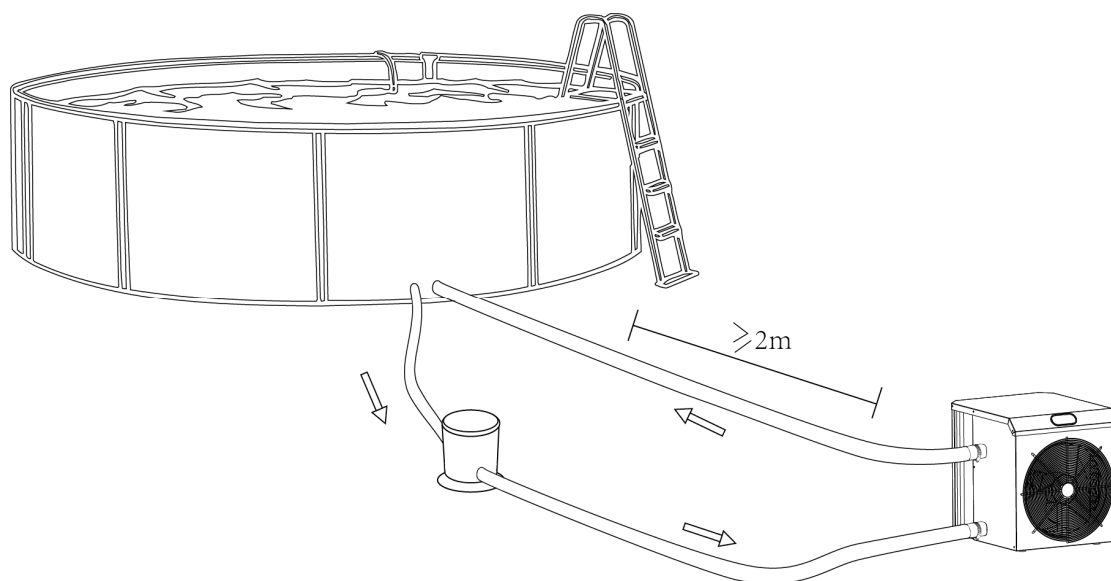

Note: Do not install the unit in a confined or insufficient ventilation location, or in a location where it may block the air intake. These locations can affect the flow air c. It will cause the air to recirculate, resulting in reduced efficiency. It even may stop the system from running.

1.2 Trial

Note: Please ensure the order of “When start, start water pump before heat pump, When finish, turn off heat pump before water pump”, otherwise it will damage the heat pump.

1.3 Connection

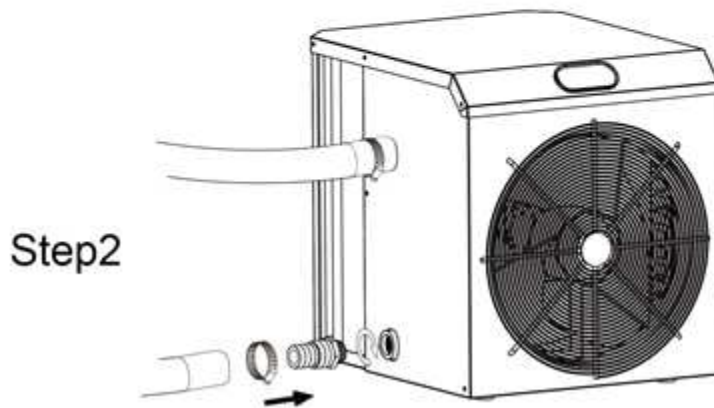
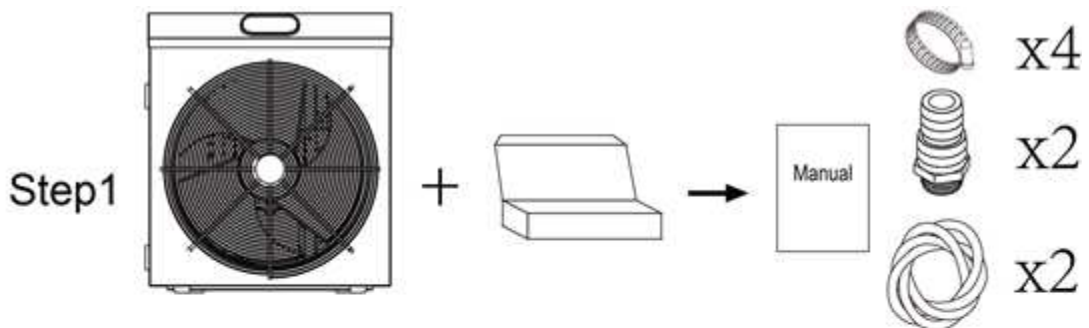

Before connecting the power supply, make sure that the power supply matches the rated power supply of the product.

Cable Selection of the Protection Device

Model		SHP03	SHP05	SHP06
Breaker	Residual-current circuit breaker	4.5	8.0	9.0
	Rated residual leakage current	30	30	30
Fuse		4.5	8.0	9.0
Power Cord (MM2)		3×1.5	3×1.5	3×1.5

※ Above data is subject to modification without notice.

Note: The above data is adapted to power cord ≤ 10m. If power cord is > 10m, wire diameter must be increased. The signal cable can be extended to 50m at most.

Pay attention:

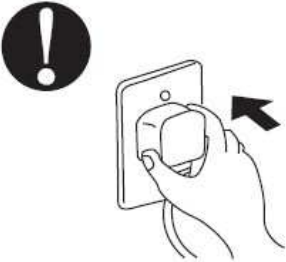
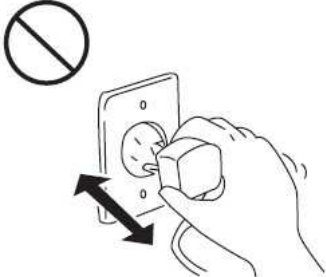
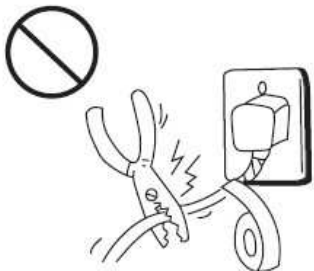
<p>Please ensure the safety of the power plug. Otherwise, it could cause electric shock or fire.</p> 	<p>Do not disconnect the power supply while the machine is running Otherwise, it could cause an electric shock or fire.</p> 	<p>Do not use damaged or substandard wires. Otherwise, it could cause an electric shock or fire.</p> 
--	---	--

After all connections are complete and checked, perform the following steps:

- 1) The user should start the water pump first to ensure no water leakage in the water pipe system; then set the thermostat at the appropriate temperature after power on.
- 2) In order to protect the machine, it has a delayed start function, after start up, the water pump start, next fan runs, and the compressor will start up automatically after about 3 minutes
- 3) Check if there is any abnormal noise when running
- 4) Check that the set temperature is appropriate

Depending on the initial temperature of the pool water and the air temperature, it may take several days to heat the water to the desired temperature. A good swimming pool cover can greatly reduce the time required.

Time delay - the heat pump has a built-in 3-minute start delay (only started when heated) to protect the circuit and avoid frequent switches causing losses. The machine will restart automatically after the delay period. Even a brief power outage can trigger this delay and prevent the machine from restarting immediately. Power on and off during this delay does not affect the 3-minute duration of the delay.

1.5 Condensate water

The air entering the heat pump is strongly cooled when heat pump heat the pool water, which may cause condensation of the evaporator fins. At higher relative humidity, condensation can reach several liters per hour. This phenomenon is sometimes mistaken for a leak.

2. Dimension

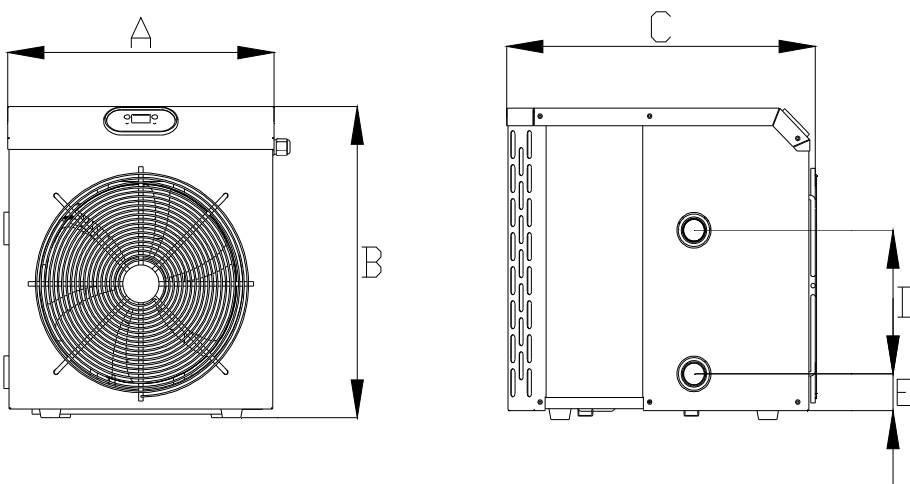

Size(mm) / Name / Model	A	B	C	D	E
SHP03	367	412	425	190	49
SHP05	445	484	503	300	49
SHP06	445	484	503	300	49

3. Technical Parameter

Model	SHP03	SHP05	SHP06
Advised pool volume	<20	<28	<35
Operating air temperature	10-43		
Performance Condition: Air 26°C, Water 26°C, Humidity 80%			
Heating capacity	3.5	5.8	7.0
Performance Condition: Air 15°C, Water 26°C, Humidity 70%			
Heating capacity	2.4	3.8	4.8
Power supply	230V/50Hz/1PH		
Advised water flux	1-2	2-3	3-4
Water pipe in-out size	32/38		
Net dimension	412x367x425	484x445x503	484x445x503
Net weight	24	34	38

Above data is subject to modification without notice.

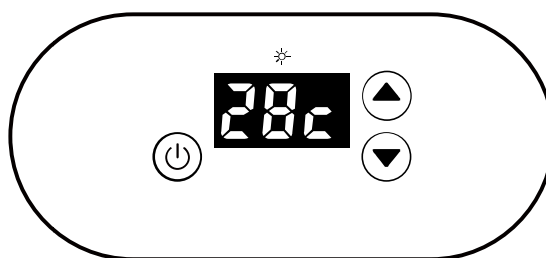

SYMBOL	DESIGNATION	OPERATION
	Power ON/OFF	Press to power on or off the heat pump
	Up/ Down	Press to set desired water temperature

4. 1 Temperature display

28°C is shown on the screen as below for your reference:



4. 2 Operation

- 5) Heat pump turn on/ turn off: when power on, press to turn on/turn off.
- 6) Water temperature Adjustment: When the heat pump is on, press or to modify the setting temperature of the water.
- 7) During heating, “” will be light: the water temperature can be adjusted to (18~40°C)
- 8) Defrosting

Automatic defrosting: When enter to automatic defrost function, the icon on the top of screen will flash; When finish defrosting, the machine switch automatically to heating function, and the icon keep lighted.

Note: The heat pump can only be operated while the water circulation/filtration system is running.

5.1 Trouble shooting for common faults

FAILURE	REASON	SOLUTION
Heat pump doesn't run	No power	Wait until the power recovers
	Power switch is off	Switch on the power
	Fuse burned	Check and change the fuse
	The breaker is off	Check and turn on the breaker
Fan running but with insufficient heating	evaporator blocked	Remove the obstacles
	Air outlet blocked	Remove the obstacles
	3 minutes start delay	Wait patiently
Display normal, but no heating	Set temp. too low	Set proper heating temp.
	3 minutes start delay	Wait patiently
If above solutions don't work, please contact your installer with detailed information and your model number. Don't try to repair it yourself.		

Note: If the following conditions happen, please stop the machine immediately, and cut off the power supply immediately, then contact your dealer:

- a) Inaccurate switch action;
- b) The fuse is frequently broken or leakage circuit breaker jumped.

5.2 Failure code

Failure code	Failure description
PP1	Water Inlet temperature sensor failure
PP2	Failure for the sensor to connect AIN2 terminal on PC board
PP3	Failure for the sensor to connect AIN3 terminal on PC board
PP4	Gas return temp sensor failure
PP5	Air temp sensor failure
PP7	Heating ambient temperature too low protection
EE1	High pressure protection
EE2	Low pressure protection
EE3	Water flow switch failure

6. Daily Maintenance and Product Repair

6. 1 Daily maintenance

- a) Properly set the temperature and humidity for a cozy environment, avoid overheating or excessive cooling.
- b) Don't put obstacles before the air inlet and outlet of the heat pump, or the efficiency of the heat pump will be reduced, even heat pump stopped.
- c) Don't put your hand or the stick into inlet or outlet, do not remove the fan mesh, otherwise the running fan might cause damage to you.
- d) Don't use or store combustible gas or liquid such as thinners, paint and fuel to avoid fire.
- e) Do not rinse the machine directly with water. It is recommended to use household neutral detergent or water to do cleaning. It is strictly forbidden to use volatile oil, gasoline, thinner and other substances.
- f) Please clean the swimming pool and filtration system regularly to avoid damage to the unit due to filter clogging.
- g) Without using in the winter, the power switch must be disconnected; unscrew the inlet pipe to clear the water inside the machine.
- h) Please check regularly the screws for looseness, check whether the wires are worn or not, and whether the connections are secure.

6. 2 Product Repair

- a) In case of abnormal conditions (abnormal noise, odor, smoke, electric leakage, etc.), please cut off the power immediately, then contact your local dealer, and inform the product model and fault details. It must be repaired by a professional. Do not disassemble and repair it yourself to avoid any danger!
- b) Before detecting and repairing the machine, you must confirm that the machine has been turned off and disconnected from the power supply; when opening the cover of the electrical box, it must be confirmed that all the indicators in the electrical box have been extinguished before operation.

